

## Exhibitor Contract

January 15-19, 2024 | Greensboro Convention Center | Greensboro, NC

### EXHIBIT BOOTH PRICING

Booth Type	Non-Member Rate — Full Payment	Member Rate — Full Payment
<span style="color: red;">■</span> 10X10 Inline	\$1,250	\$1,000
<span style="color: blue;">■</span> 10X10 End Booth	\$1,550	\$1,240
<span style="color: black;">■</span> 2-Booth Endcap	\$3,100	\$2,480
<span style="color: yellow;">■</span> 4-Booth Endcap	\$5,550	\$4,440
<span style="color: orange;">■</span> 4-Booth Island	\$6,200	\$4,960

**BOOTH FEE** \$ \_\_\_\_\_

### NCNLA MEMBERSHIP

Are you a current NCNLA member?

Yes  No

*Membership will be verified and invoiced if needed.*

I am a returning exhibitor (booth # \_\_\_\_\_) and wish to:  Stay in Current Location  Relocate  Expand

*Relocation and expansion requests will be handled after August 1, 2023.*

### MAIN CONTACT INFORMATION

Company \_\_\_\_\_  
 Contact Name \_\_\_\_\_  
 Address \_\_\_\_\_  
 City \_\_\_\_\_ State \_\_\_\_\_ Zip \_\_\_\_\_  
 Phone \_\_\_\_\_ Fax \_\_\_\_\_  
 Email (required) \_\_\_\_\_  
 Company email (to appear in Showbook) \_\_\_\_\_  
 Website \_\_\_\_\_

### PAYMENT TERMS

A non-refundable \$200 deposit must be submitted to NCNLA no later than June 1, 2023 in order to retain a specific booth space for the Marketplace. The remaining balance must be paid in full no later than August 1, 2023. Failure to comply with these deadlines will result in forfeiture of all rights, claims and reservations to specific booth(s) as previously assigned and pricing will be adjusted to reflect the most current rate.

Exhibitor contracts submitted after August 1, 2023 must include payment in full.

All payments are to be made in US funds.

### BILLING CONTACT INFORMATION

Contact Name \_\_\_\_\_  
 Address \_\_\_\_\_  
 Phone \_\_\_\_\_  
 Email (required) \_\_\_\_\_

For payments made prior to August 1, 2023, select an option:

\$200 deposit  Full Payment

### CANCELLATION POLICY

Cancellation/refund requests must be submitted in writing to NCNLA. Requests submitted by September 1, 2023 will receive a full refund, less the non-refundable \$200 deposit. Requests submitted by November 1, 2023 will receive a 50-percent refund, less the \$200 deposit. Requests submitted after November 1, 2023 will **not** be considered. Exhibitors who fail to attend the event forfeit any and all payments.

### EXHIBITORS

Invoice Me (*Invoice with payment link will be sent via email provided under Billing Contact Information.*)  
 Check # \_\_\_\_\_

### EXHIBITOR NAME BADGES

Each 10'x10' space receives two name badges. Additional badges are \$20 each, if purchased by the early-bird deadline. After the deadline, badges are \$25 each.

A Marketplace/Exhibitor name badge does not provide access to the Education Program at the Sheraton.

### EXHIBITOR SIGNATURE

I hereby agree to all terms, conditions, rules and regulations governing the opportunity to exhibit at the Green & Growin' Marketplace as set forth in this contract.

Signature \_\_\_\_\_ Date \_\_\_\_\_

*Please make a copy and return original to NCNLA at address above.*

### Questions, comments or suggestions?

Contact the NCNLA office at [kstansbury@ncnla.com](mailto:kstansbury@ncnla.com) or (919) 816-9119.

### SHOW DATES/HOURS

<b>Thu, Jan. 18</b>	<b>9 AM-5 PM</b>
<b>Fri, Jan. 19</b>	<b>9 AM-3 PM</b>
<b>MOVE-IN</b>	<b>Tue, Jan. 16 8 AM-5 PM</b>
	<b>Wed, Jan. 17 8 AM-1 PM</b>
<b>MOVE-OUT</b>	<b>Fri, Jan. 19 3 PM-10 PM</b>

# GREEN & GROWIN' 24 MARKETPLACE RULES & REGULATIONS

**BOOTH DETAILS:** Exhibit booths are sold in 10'x10' increments. Each booth includes an 8-foot high back drape, 3-foot high side drapes and company sign. Additional furnishings (e.g., tables, chairs, carpet, etc.) may be rented directly from exposition company.

**NAME BADGES:** Each 10'x10' booth receives two Marketplace name badges. Additional badges may be purchased online at the Exhibitor Service Center for \$20 each, if purchased by the early-bird deadline. After the deadline, badges are \$25 each. A Marketplace name badge does not provide access to the Education Program at the Sheraton.

**PAYMENTS:** A non-refundable \$200 deposit must be submitted to NCNLA no later than June 1, 2023 in order to retain a specific booth for the 2024 Marketplace. The remaining balance must be paid in full no later than August 1, 2023. Failure to comply with these deadlines will result in forfeiture of all rights, claims and reservations to specific booth(s) as previously assigned and pricing will be adjusted to reflect the most current rate.

**CANCELLATIONS:** Cancellation/refund requests must be submitted in writing to NCNLA via mail or email (kstansbury@ncnla.com). Requests submitted by September 1, 2023 will receive a full refund, less the non-refundable \$200 deposit. Requests submitted by November 1, 2023 will receive a 50-percent refund, less the \$200 deposit. Requests submitted after November 1, 2023 will not be considered. Exhibitors who cancel or fail to attend the event forfeit all rights, claims and reservations to specific booth(s) as previously assigned. Exhibitors who fail to attend the event also forfeit all payments. No exceptions.

**SUBLETTING OF SPACE:** An exhibitor may not sublet their exhibit space or any part thereof for any reason.

**DISPLAY RESTRICTIONS:** An exhibitor may not place display material outside their booth boundary. Aisles must be kept clear in accordance with Fire Marshal regulations. Display material that violates the Rules & Regulations will be removed at exhibitor's expense. Booth displays must allow exhibitor personnel to work within the confines of the booth. Selling within the aisles is strictly prohibited.

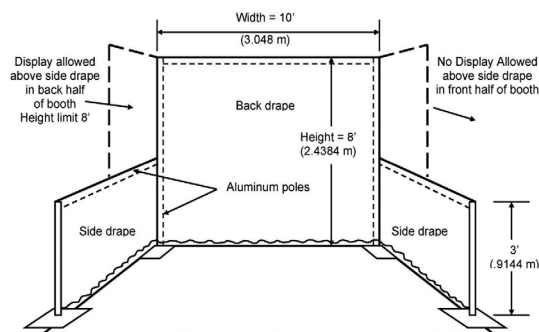

Displays and/or products located more than five feet from the back of the booth are not permitted to extend above the side curtains. This allows attendees to have a clear line of vision to all neighboring booths.

Items located within five feet of the back of the booth cannot extend above 15 feet. End booths and end caps may not block visibility down adjoining aisles and must plan their displays accordingly.

Signs or other items intended to hang from the ceiling must be approved by Show Management.

**DIRECT SALES:** While the show is in progress, the direct sale/removal of any display material from a booth is strictly prohibited. For security purposes, attendees/buyers are not permitted to exit the Marketplace with any purchased items before 3:00 PM, Friday. Exhibitors must provide an itemized bill-of-sale for all items sold. Exhibitors who allow attendees/buyers to remove purchased items before 3:00 PM, Friday risk losing the opportunity to exhibit at subsequent tradeshows.

**UNAUTHORIZED SOLICITATIONS:** Selling on the Marketplace floor by individuals who are not exhibiting is strictly prohibited. If you witness this type of activity, contact Show Management immediately.

**SETUP:** The Coliseum is a non-union facility; therefore, NCNLA provides complimentary move-in/move-out assistance, including hand trucks, dollies and forklifts. During designated move-in/move-out hours, display material requiring a significant amount of assistance may incur a fee of \$75/hour, which will be billed to the exhibitor. Assistance provided outside designated move-in/move-out hours will be billed to the exhibitor at the rate of \$150/hour.

**OPERATIONS:** Exhibit booths must be staffed by at least one person during show hours. Exhibitor personnel must wear Marketplace name badges. Mechanical/electrical devices producing sound/light cannot interfere with adjacent exhibitors. Show Management reserves the right to determine acceptable sound/light levels.

**ACCESS TO MARKETPLACE:** Exhibitor access to the Marketplace is permitted ½-hour prior and ½-hour after normal show hours. Exhibitor personnel requiring access outside specified times must obtain a special pass from Show Management.

**LATE ARRIVAL:** In the event of delayed/late arrival, exhibitor must notify Show Management of their anticipated arrival time no later than 4:00 PM, Tuesday. Special arrangements may be required to allow for after-hours move-in.

**TEAR-DOWN:** Exhibitor agrees not to begin tear-down until the show officially closes at 3:00 PM, Friday. Early tear-downs risk losing the opportunity to exhibit at subsequent tradeshows. During tear-down, it is the sole responsibility of the exhibitor to ensure the safety of their display material. For security purposes, exhibitor personnel must wear Marketplace name badges during move-out. If product is dismantled and/or shipped by exposition company, exhibitor must remain with property until exposition company representative arrives at booth. All booth material must be out of the Marketplace by 10:00 PM, Friday. If exhibitor is unable to remove items by that time, exhibitor must arrange for storage with exposition company.

**SECURITY:** Security will be onsite 24 hours a day beginning Wednesday. Show Management is not responsible for lost or damaged property due to theft, fire, water, accident or other force majeure events. Insurance, if desired, is the responsibility of the exhibitor.

**PROHIBITED ITEMS:** The Coliseum prohibits distribution of helium-filled balloons and/or adhesive-backed decals. Any expense to remove such items will be billed to the violating exhibitor. Food items to be distributed by exhibitor personnel must be approved by Show Management at least four (4) weeks in advance of the show.

**HEALTH, SAFETY AND WELFARE:** Exhibitor agrees to comply with local, city, state and federal laws, ordinances and regulations addressing public health, safety and welfare. Smoking in the Coliseum is strictly prohibited. Gasoline-powered equipment should contain no more than two gallons of gas. Battery cables must be removed and taped to avoid potential sparks. Gas tanks must have a locking gas cap or be adequately sealed by tape. Cut trees, greenery and pine straw must be properly treated with a fire retardant to prevent fire hazards.

**LIABILITY:** Exhibitor hereby waives any and all claims against NCNLA, its board of directors, members, staff, contractors, volunteers and Coliseum employees resulting from injury, loss, theft, damage or destruction of property; contract revocation for violation of the Rules & Regulations; or force majeure events that require show cancellation.

**ACCEPTANCE:** A signed Exhibitor Contract shall signify Exhibitor's acceptance of the Rules & Regulations as outlined herein.